

METHOD 5041A

ANALYSIS FOR DESORPTION OF SORBENT CARTRIDGES FROM  
VOLATILE ORGANIC SAMPLING TRAIN (VOST)

1.0 SCOPE AND APPLICATION

1.1 This method describes the desorption of volatile principal organic hazardous constituents (POHCs) collected from the stack gas effluents of hazardous waste incinerators using the Volatile Organic Sampling Train (VOST) methodology (1) with analysis by GC/MS (Method 8260). For a comprehensive description of the VOST sampling methodology see Method 0030. The following compounds may be determined by this method:

Compound	CAS No. <sup>a</sup>
Acetone	67-64-1
Acrylonitrile	107-13-1
Benzene	71-43-2
Bromodichloromethane	75-27-4
Bromoform <sup>b</sup>	75-25-2
Bromomethane <sup>c</sup>	74-83-9
Carbon disulfide	75-15-0
Carbon tetrachloride	56-23-5
Chlorobenzene	108-90-7
Chlorodibromomethane	124-48-1
Chloroethane <sup>c</sup>	75-00-3
Chloroform	67-66-3
Chloromethane <sup>c</sup>	74-87-3
Dibromomethane	74-95-3
1,1-Dichloroethane	75-35-3
1,2-Dichloroethane	107-06-2
1,1-Dichloroethene	75-35-4
trans-1,2-Dichloroethene	156-60-5
1,2-Dichloropropane	78-87-5
cis-1,3-Dichloropropene	10061-01-5
trans-1,3-Dichloropropene	10061-02-6
Ethylbenzene <sup>b</sup>	100-41-4
Iodomethane	74-88-4
Methylene chloride	75-09-2
Styrene <sup>b</sup>	100-42-5
1,1,2,2-Tetrachloroethane <sup>b</sup>	79-34-5
Tetrachloroethene	127-18-4
Toluene	108-88-3
1,1,1-Trichloroethane	71-55-6
1,1,2-Trichloroethane	79-00-5

(continued)

Compound	CAS No. <sup>a</sup>
Trichloroethene	79-01-6
Trichlorofluoromethane	75-69-4
1,2,3-Trichloropropane <sup>b</sup>	96-18-4
Vinyl chloride <sup>c</sup>	75-01-4
Xylenes <sup>b</sup>	

<sup>a</sup> Chemical Abstract Service Registry Number.

<sup>b</sup> Boiling point of this compound is above 120°C. Method 0030 is not appropriate for quantitative sampling of this analyte.

<sup>c</sup> Boiling point of this compound is below 30°C. Special precautions must be taken when sampling for this analyte by Method 0030. Refer to Sec. 1.3 for discussion.

1.2 This method is most successfully applied to the analysis of non-polar organic compounds with boiling points between 30°C and 100°C. Data are applied to the calculation of destruction and removal efficiency (DRE), with limitations discussed below.

1.3 This method may be applied to analysis of many compounds which boil above 100°C, but Method 0030 is always inappropriate for collection of compounds with boiling points above 120°C. All target analytes with boiling points greater than 120°C are so noted in the target analyte list presented in Sec. 1.1. Use of Method 0030 for collection of compounds boiling between 100°C and 120°C is often possible, and must be decided based on case by case inspection of information such as sampling method collection efficiency, tube desorption efficiency, and analytical method precision and bias. An organic compound with a boiling point below 30°C may break through the sorbent under the conditions used for sample collection. Quantitative values obtained for compounds with boiling points below 30°C must be qualified, since the value obtained represents a minimum value for the compound if breakthrough has occurred. In certain cases, additional QC measures may have been taken during sampling very low boilers with Method 0030. This information should be considered during the data interpretation stage.

1.4 When Method 5041 is used for survey analyses, values for compounds boiling above 120°C may be reported and qualified since the quantity obtained represents a minimum value for the compound. These minimum values should not be used for trial burn DRE calculations or to prove insignificant risk.

1.5 The VOST analytical methodology can be used to quantitate volatile organic compounds that are insoluble or slightly soluble in water. When volatile, water soluble compounds are included in the VOST organic compound analyte list, quantitation limits can be expected to be approximately ten times higher than quantitation limits for water insoluble compounds (if the compounds can be recovered at all) because the purging efficiency from water (and possibly from Tenax-GC®) is poor.

1.6 Overall sensitivity of the method is dependent upon the level of interferences encountered in the sample and the presence of detectable concentrations of volatile POHCs in blanks. The target detection limit of this method is 0.1 µg/m<sup>3</sup> (ng/L) of flue gas, to permit calculation of a DRE equal to or greater than 99.99% for volatile POHCs which may be present in the waste stream at 100 ppm. The upper end of the range of applicability of this method is limited by the dynamic range of the

analytical instrumentation, the overall loading of organic compounds on the exposed tubes, and breakthrough of the volatile POHCs on the sorbent traps used to collect the sample. Method 8260 presents method detection limits for a range of volatile compounds analyzed by this method interfaced to a GC/MS with wide bore capillary methodology.

1.7 This method is restricted to use by, or under the supervision of, analysts experienced in the use of sorbent media, purge-and-trap systems, and gas chromatograph/mass spectrometers, and skilled in the interpretation of mass spectra and their use as a quantitative tool.

## 2.0 SUMMARY OF METHOD

2.1 The sorbent tubes are thermally desorbed by heating and purging with organic-free helium. The gaseous effluent from the tubes is bubbled through pre-purged organic-free reagent water and trapped on an analytical sorbent trap in a purge-and-trap unit (Figure 2).

2.2 After desorption, the analytical sorbent trap is heated rapidly and the gas flow from the analytical trap is directed to the head of a wide-bore column under subambient conditions.

2.3 The volatile organic compounds desorbed from the analytical trap are determined by Method 8260 (Figure 3).

## 3.0 INTERFERENCES

3.1 Sorbent tubes which are to be analyzed for volatile organic compounds can be contaminated by diffusion of volatile organic compounds (particularly Freon® refrigerants and common organic solvents) through the external container [even through a polytetrafluoroethylene (PTFE)-lined screw cap on a glass container] and the Swagelok® sorbent tube caps during shipment and storage. The sorbent tubes can also be contaminated if organic solvents are present in the analytical laboratory. The use of blanks is essential to assess the extent of any contamination. Field blanks need to be prepared and taken to the field. The end caps of the tubes are removed for the period of time required to exchange two pairs of traps on the VOST sampling apparatus. The tubes are recapped and shipped and handled exactly as the actual field samples are shipped and handled. At least one pair of field blanks is included with each six pairs of sample cartridges collected.

3.2 At least one pair of blank cartridges (one Tenax-GC®, one Tenax-GC®/charcoal) must be included with shipment of cartridges to a hazardous waste incinerator site as trip blanks. These trip blanks are treated like field blanks except that the end caps are not removed during storage at the site. This pair of traps are analyzed to monitor potential contamination which may occur during storage and shipment.

3.3 Analytical system blanks are needed to demonstrate that contamination of the purge-and-trap unit and the gas chromatograph/mass spectrometer has not occurred or that, in the event of analysis of sorbent tubes with very high concentrations of organic compounds, no compound carryover is occurring. Tenax® from the same preparation batch as the Tenax® used for field sampling should be used in the preparation of the method (laboratory) blanks. A sufficient number of cleaned Tenax® tubes from the same batch as the field samples should be reserved in the laboratory for use as blanks.

3.4 Cross contamination can occur whenever low-concentration samples are analyzed after high-concentration samples, or when several high-concentration samples are analyzed sequentially.

When an unusually concentrated sample is analyzed, this analysis should be followed by a method blank to establish that the analytical system is free of contamination. If analysis of a blank demonstrates that the system is contaminated, an additional bake cycle should be used. If the analytical system is still contaminated after additional baking, routine system maintenance should be performed: the analytical trap should be changed and conditioned, routine column maintenance should be performed (or replacement of the column and conditioning of the new column, if necessary), and bakeout of the ion source (or cleaning of the ion source and rods, if required). After system maintenance has been performed, analysis of a blank is needed to demonstrate that the cleanliness of the system is acceptable.

3.5 Impurities in the purge gas and from organic compounds out-gassing in tubing account for the majority of contamination problems. The analytical system must be demonstrated to be free from contamination under the conditions of the analysis by analyzing two sets of clean, blank sorbent tubes with organic-free reagent purge water as system blanks. The analytical system is acceptably clean when these two sets of blank tubes show values for the analytes which are within one standard deviation of the normal system blank. Use of plastic coatings, non-PTFE thread sealants, or flow controllers with rubber components should be avoided.

3.6 VOST tubes are handled in the laboratory to spike standards and to position the tubes within the desorption apparatus. When sorbent media are handled in the laboratory atmosphere, contamination is possible if there are organic solvents in use anywhere in the laboratory. It is therefore necessary to make daily use of system blanks to monitor the cleanliness of the sorbents and the absence of contamination from the analytical system. A single set of system blank tubes shall be exposed to normal laboratory handling procedures and analyzed as a sample. This sample should be within one standard deviation of normal VOST tube blanks to demonstrate lack of contamination of the sorbent media.

3.7 If the emission source has a high concentration of non-target organic compounds (for example, hydrocarbons at concentrations of hundreds of ppm), the presence of these non-target compounds will interfere with the performance of the VOST analytical methodology. If one or more of the compounds of interest saturates the chromatographic and mass spectrometric instrumentation, no quantitative calculations can be made and the tubes which have been sampled under the same conditions will yield no valid data for any of the saturated compounds. In the presence of a very high organic loading, even if the compounds of interest are not saturated, the instrumentation is so saturated that the linear range has been surpassed. When instrument saturation occurs, it is possible that compounds of interest cannot even be identified correctly because a saturated mass spectrometer may mis-assign masses. Even if compounds of interest can be identified, accurate quantitative calculations are impossible at detector saturation. No determination can be made at detector saturation, even if the target compound itself is not saturated. At detector saturation, a negative bias will be encountered in analytical measurements and no accurate calculation can be made for the Destruction and Removal Efficiency if analytical values may be biased negatively.

3.8 The recoveries of the surrogate compounds, which are spiked on the VOST tubes immediately before analysis, should be monitored carefully as an overall indicator of the performance of the methodology. Since the matrix of stack emissions is so variable, only a general guideline for recovery of 50-150% can be used for surrogates. The analyst cannot use the surrogate recoveries as a guide for correction of compound recoveries. The surrogates are valuable only as a general indicator of correct operation of the methodology. If surrogates are not observed or if recovery of one or more of the surrogates is outside the 50-150% range, the VOST methodology is not operating correctly. The cause of the failure in the methodology is not obvious. The matrix of stack emissions contains large amounts of water, may be highly acidic, and may contain large amounts of target and

non-target organic compounds. Chemical and surface interactions may be occurring on the tubes. If recoveries of surrogate compounds are extremely low or surrogate compounds cannot even be identified in the analytical process, then failure to observe an analyte may or may not imply that the compound of interest has been removed from the emissions with a high degree of efficiency (that is, the DRE for that analyte is high).

#### 4.0 APPARATUS AND MATERIALS

4.1 Tube desorption apparatus: Acceptable performance of the methodology requires:

- 1) temperature regulation to ensure that tube temperature during desorption is regulated to  $180^{\circ}\text{C} \pm 10^{\circ}$ ;
- 2) good contact between tubes and the heating apparatus to ensure that the sorbent bed is thoroughly and uniformly heated to facilitate desorption of organic compounds; and
- 3) gas-tight connections to the ends of the tubes to ensure flow of desorption gas through the tubes without leakage during the heating/desorption process. A simple clamshell heater which will hold tubes which are 3/4" in outer diameter will perform acceptably as a desorption apparatus.

4.2 Purge-and-trap device: The purge-and-trap device is described in Method 5030, Sec. 4.0.

4.2.1 The cartridge thermal desorption apparatus is connected to the sample purge vessel by 1/16" PTFE (e.g., Teflon®) tubing (unheated transfer line). The tubing which connects the desorption chamber to the sample purge vessel should be as short as is practical.

4.2.2 The sample purge vessel is required to hold 5 mL of organic-free reagent water, through which the gaseous effluent from the VOST tubes is routed.

4.3 The gas chromatograph/mass spectrometer/data system and recommended GC columns are described in Method 8260, Sec. 4.0.

4.4 Wrenches: 9/16", 1/2", 7/16", and 5/16".

4.5 PTFE (e.g., Teflon®) tubing: 1/16" diameter.

4.6 Syringes: 25  $\mu\text{L}$  syringes (2), 10  $\mu\text{L}$  syringes (2).

4.7 Fittings: 1/4" nuts, 1/8" nuts, 1/16" nuts, 1/4" to 1/8" union, 1/4" to 1/4" union, 1/4" to 1/16" union.

4.8 Adjustable stand to raise the level of the desorption unit, if necessary.

4.9 Volumetric flasks: 5 mL, class A with ground glass stopper.

4.10 Injector port or equivalent, heated to  $180^{\circ}\text{C}$  for loading standards onto VOST tubes prior to analysis.

4.11 Vials: 2 mL, with PTFE-lined screw caps or crimp tops.

4.12 Syringe: 5 mL, gas-tight with shutoff valve.

## 5.0 REAGENTS

5.1 Reagent grade chemicals shall be used in all tests. Unless otherwise indicated, it is intended that all reagents shall conform to the specifications of the Committee on Analytical Reagents of the American Chemical Society, where such specifications are available. Other grades may be used, provided it is first ascertained that the reagent is of sufficiently high purity to permit its use without lessening the accuracy of the determination.

5.2 Organic-free reagent water - All references to water in this method refer to organic-free reagent water, as defined in Chapter One.

**NOTE:** It is advisable to maintain the stock of organic-free reagent water generated for use in the purge-and-trap apparatus with a continuous stream of inert gas bubbled through the water. Continuous bubbling of the inert gas maintains a positive pressure of inert gas above the water as a safeguard against contamination.

5.3 Methanol, CH<sub>3</sub>OH. Pesticide quality or equivalent. To avoid contamination with other laboratory solvents, it is advisable to maintain a separate stock of methanol for the preparation of standards for VOST analysis and to regulate the use of this methanol very carefully.

5.4 Surrogate standards: The recommended surrogates are listed in Method 8260, Sec. 5.0. A stock surrogate compound solution in high purity methanol should be prepared as described in Sec. 5.0, Method 8260, and a surrogate standard spiking solution should be prepared from the stock at a concentration of 250 µg/10 mL in high purity methanol. Each pair of VOST tubes (or each individual VOST tube, if the tubes are analyzed separately) must be spiked with 10 µL of the surrogate spiking solution prior to GC/MS analysis.

5.5 Internal standards: The recommended internal standards for GC/MS analysis are listed in Method 8260, Sec. 5.0. Prepare internal standard stock and secondary dilution standards in high purity methanol using the procedures described in Sec. 5.0 of Method 8260. The secondary dilution standard should be prepared at a concentration of 25 mg/L of each of the internal standard compounds. Addition of 10 µL of this internal standard solution to each pair of VOST tubes (or to each VOST tube, if the tubes are analyzed individually) is the equivalent of 250 ng total.

5.6 Great care must be taken to maintain the integrity of all standard solutions. All standards of volatile compounds in methanol should be stored at -10°C to -20°C in amber bottles with PTFE-lined screw caps or crimp tops. In addition, careful attention must be paid to the use of syringes designated for a specific purpose or for use with only a single standard solution since cross contamination of volatile organic standards can occur very readily.

## 6.0 SAMPLE COLLECTION, PRESERVATION, AND HANDLING

6.1 See Method 0030 or Method 0031 for VOST Sampling Methodology.

6.2 VOST samples are collected on paired cartridges. The first of the pair of sorbent cartridges is packed with approximately 1.6 g of Tenax-GC® resin. The second cartridge of the pair is packed with Tenax-GC® and petroleum based charcoal (3:1 by volume; approximately 1 g of each). In sampling, the emissions gas stream passes through the Tenax-GC® layer first and then through the charcoal layer. The Tenax-GC® is cleaned and reused; charcoal is not reused when tubes are prepared. Sorbent is cleaned and the tubes are packed. The tubes are desorbed and subjected to a blank check prior to being sent to the field. When the tubes are used for sampling (see Figure 5 for a schematic diagram of the VOST), cooling water is circulated to the condensers and the temperature of the cooling water is maintained near 0°C. The end caps of the sorbent cartridges are placed in a clean, screw capped glass container during sample collection.

6.3 After the apparatus is leak checked, sample collection is accomplished by opening the valve to the first condenser, turning on the pump, and sampling at a rate of 1 L/min for 20 minutes. The volume of sample for any pair of traps should not exceed 20 liters. An alternative set of conditions for sample collection requires sampling at a reduced flow rate, where the overall volume of sample collected is 5 liters at a rate of 0.25 L/min for 20 minutes. The 20 minute period is necessary for collecting an integrated sample.

6.4 Following collection of 20 Liters of sample, the train is leak checked a second time at the highest pressure drop encountered during the run to minimize the chance of vacuum desorption of organics from the Tenax®.

6.5 The train is returned to atmospheric pressure and the two sorbent cartridges are removed. The end caps are replaced and the cartridges are placed in a suitable environment for storage and transport until analysis. The sample is considered invalid if the leak test does not meet specifications.

6.6 A new pair of cartridges is placed in the VOST, the VOST is leak checked, and the sample collection process is repeated until all pairs of traps have been exposed.

6.7 All sample cartridges are kept in coolers on cold packs after exposure and during shipment. Upon receipt at the laboratory, the cartridges are stored in a refrigerator at 4°C until analysis. The maximum storage time between sampling and analysis is 14 days.

## 7.0 PROCEDURE

7.1 Recommended operating conditions for cartridge desorber and purge-and-trap unit, are:

### Cartridge Desorption Oven

Desorb Temperature	180°C
Desorb Time	11 minutes
Desorption Gas Flow	40 mL/min
Desorption/Carrier Gas	Helium, Grade 5.0

### Purge-and-Trap Concentrator

Analytical Trap Desorption Flow	2.5 mL/min helium
Purge Temperature	Ambient
Purge Time	11 minutes
Analytical Trap Desorb Temp.	180°C
Analytical Trap Desorb Time	5 minutes

### Gas Chromatograph

Column	30 m x 0.53 mm ID, coated with DB-624 (J&W Scientific), 3 µm film thickness, or equivalent.
Carrier Gas Flow	15 mL/min
Makeup Gas Flow	15 mL/min
Injector Temperature	200°C
Transfer Oven Temperature	240°C
Initial Temperature	5°C
Initial Hold Time	2 minutes
Program Rate	6°C/min
Final Temperature	240°C
Final Hold Time	1 minute or until elution ceases

### Mass Spectrometer

Manifold Temperature	105°C
Scan Rate	1 sec/cycle
Mass Range	35-260 amu
Electron Energy	70 eV (nominal)
Source Temperature	According to manufacturer's specifications

7.2 Each GC/MS system must be hardware tuned to meet the BFB criteria in Method 8260.

7.3 Assemble and operate a purge-and-trap device as per Method 5030.

7.4 Connect the purge-and-trap device to a gas chromatograph.

7.5 Assemble a VOST tube desorption apparatus which meets the requirements of Sec. 4.1.

7.6 Connect the VOST tube desorption apparatus to the purge-and-trap unit.

7.7 Spiking standards onto VOST tubes: For this procedure, the system will be calibrated using the internal standard procedure. Internal standards, surrogates, and calibration standards in methanolic solution will be spiked onto cleaned VOST tubes for proper calibration of the system. These standards are spiked onto VOST tubes using the flash evaporation technique. To perform flash evaporation, the injector of a gas chromatograph or an equivalent piece of equipment is required.

7.7.1 Prepare a syringe with the appropriate volume of methanolic standard solution (either surrogates, internal standards, or calibration compounds).

7.7.2 With the injector port heated to 180°C, and with an inert gas flow of 10 mL/min through the injector port, connect the paired VOST tubes (connected as in Figure 1, with gas flow in the same direction as the sampling gas flow) to the injector port; tighten with a wrench so that there is no leakage of gas. If separate tubes are being analyzed, an individual Tenax® or Tenax®/charcoal tube is connected to the injector.

7.7.3 After directing the gas flow through the VOST tubes, slowly inject the first standard solution over a period of 25 seconds. Wait for 5 seconds before withdrawing the syringe from the injector port.

7.7.4 Inject a second standard (if required) over a period of 25 seconds and wait for 5 seconds before withdrawing the syringe from the injector port.



7.7.5 Repeat the sequence above, as required, until all of the necessary compounds are spiked onto the VOST tubes.

7.7.6 Wait for 30 seconds, with gas flow, after the last spike before disconnecting the tubes. The total time the tubes are connected to the injector port with gas flow should not exceed 2.5 minutes. Total gas flow through the tubes during the spiking process should not exceed 25 mL to prevent break-through of adsorbed compounds during the spiking process. To allow more time for connecting and disconnecting tubes, an on/off valve may be installed in the gas line to the injector port so that gas is not flowing through the tubes during the connection/disconnection process.

7.8 Prepare the purge-and-trap unit with 5 mL of organic-free reagent water in the purge vessel.

7.9 Connect the paired VOST tubes to the gas lines in the tube desorption unit. The tubes must be connected so that the gas flow during desorption will be opposite to the flow of gas during sampling: i.e., the tube desorption gas passes through the charcoal portion of the tube first. An on/off valve may be installed in the gas line leading to the tube desorption unit in order to prevent flow of gas through the tubes during the connection process.

7.10 Initiate tube desorption/purge and heating of the VOST tubes in the desorption apparatus.

7.11 Cool the oven of the gas chromatograph to subambient temperature with liquid nitrogen.

7.12 Prepare the GC/MS system for data acquisition as per Method 8260.

7.13 At the conclusion of the tube/water purge time, attach the analytical trap to the gas chromatograph, adjust the purge-and-trap device to the desorb mode, and initiate the gas chromatographic program and the GC/MS data acquisition. Perform the remainder of the purge and trap process as described in Method 5030, Sec. 7.

7.14 Initial calibration for the analysis of VOST tubes: It is essential that calibration be performed in the mode in which analysis will be performed. If tubes are being analyzed as pairs, calibration standards should be prepared on paired tubes. If tubes are being analyzed individually, a calibration should be performed on individual Tenax® only tubes and Tenax®/charcoal tubes.

7.14.1 Prepare the calibration standards by spiking VOST tubes using the procedure described in Sec. 7.7. Spike each pair of VOST tubes (or each of the individual tubes) immediately before analysis. Perform the calibration analyses in order from low concentration to high to minimize the compound carryover. Add 5.0 mL of organic-free reagent water to the purging vessel. Initiate tube desorb/purge according to the procedure.

7.14.2 Continue the initial calibration process as described in Method 8260, Sec. 7.0. The same criteria for SPCC, CCC and linearity must be met.

7.15 GC/MS Calibration Verification

7.15.1 Prior to the analysis of samples, purge 5-50 ng of the 4-bromofluorobenzene standard. The resultant mass spectrum for BFB must meet all of the criteria given in Method 8260 before sample analysis begins. These criteria must be demonstrated every twelve hours of operation.

7.15.2 Perform calibration verification as per Method 8260, Sec. 7.0. The same criteria for SPCC, linearity and internal standard response check must be met. See the next section for special guidance on the CCCs.

7.15.3 If the percent difference for any compound is greater than 20, the laboratory should consider this a warning limit. Benzene, toluene, and styrene will have problems with response factors if Tenax® decomposition occurs (either as a result of sampling exposure or temperature degradation), since these compounds are decomposition products of Tenax®. If the percent difference for each CCC is less than 25%, the initial calibration is assumed to be valid. If the criterion of percent difference less than 25% is not met for any one CCC, corrective action MUST be taken. If a source of the problem cannot be determined after corrective action is taken, a new five-point calibration curve MUST be generated. The criteria for the CCCs MUST be met before quantitative analysis can begin.

7.15.4 Internal standard responses and retention times in the calibration verification standard must be evaluated immediately after or during data acquisition. A factor which may influence the retention times of the internal standards on sample tubes is the level of overall organic compound loading on the VOST tubes. If the VOST tubes are very highly loaded with either a single compound or with multiple compounds, retention times for standards and compounds of interest will be affected. If the area for the primary ion of any of the internal standards changes by a factor of two (-50% to +100%) from the last calibration verification standard, the gas chromatograph and mass spectrometer should be inspected for malfunctions and corrections must be made, as appropriate. If the level of organic loading of samples is high, areas for the primary ions of both compounds of interest and standards will be adversely affected. Calibration verification standards should not be subject to variation, since the concentrations of organic compounds on these samples are set to be within the linear range of the instrumentation. If instrument malfunction has occurred, analyses of samples performed under conditions of malfunction may be invalidated.

## 7.16 GC/MS Analysis of Samples

7.16.1 Set up the cartridge desorption unit, purge-and-trap unit (Method 5030), and GC/MS (Method 8260) as described above or as described in the indicated methods.

7.16.2 BFB tuning criteria and GC/MS calibration verification criteria in Method 8260 must be met before analyzing samples. (See Sec. 7.15)

7.16.3 Adjust the helium purge gas flow rate (through the cartridges and purge vessel) to approximately 40 mL/min. Optimize the flow rate to provide the best response for chloromethane and bromoform, if these compounds are analytes. A flow rate which is too high reduces the recovery of chloromethane, and an insufficient gas flow rate reduces the recovery of bromoform.

7.16.4 The first analysis performed after the tuning check and the calibration or calibration verification should be a method blank. The method blank consists of clean VOST tubes (both Tenax® and Tenax®/charcoal) which are spiked with surrogate compounds and internal standards according to the procedure described in Sec. 7.7. The tubes which are used for the method blanks should be from the same batch of sorbent as the sorbent used for the field samples. After the tubes are cleaned and prepared for shipment to the field, sufficient pairs of tubes should be retained from the same batch in the laboratory to provide method blanks during the analysis.

7.16.5 Use organic-free reagent water as described in Chapter One for the purge vessel.

7.16.6 If the analysis of a pair of VOST tubes has a concentration of analytes that exceeds the initial calibration range, no reanalysis of desorbed VOST tubes is possible. An additional calibration point can be added to bracket the higher concentration encountered in the samples so that the calibration database encompasses six or more points. Alternatively, the data may be flagged in the report as "extrapolated beyond the upper range of the calibration."

7.16.7 The use of the secondary ions shown in Method 8260 is permissible only in the case of interference with the primary quantitation ion. Use of secondary ions to calculate compound concentration in the case of saturation of the primary ion is not an acceptable procedure, since a negative bias of an unpredictable magnitude is introduced into the quantitative data when saturation of the mass spectrum of a compound is encountered.

7.16.8 If high organic loadings, either of a single compound or of multiple compounds, are encountered, it is vital that a method blank be analyzed prior to the analysis of another sample to demonstrate that no compound carryover is occurring. If concentrations of organic compounds are sufficiently high that carryover problems are profound, extensive bakeout of the purge-and-trap unit is necessary. More extensive guidance on corrective maintenance of the purge and trap and GC/MS system are found in Sec. 7.0 of their respective methods (Method 5030 and Method 8260).

7.17 Qualitative analysis: Follow the procedure on qualitative analysis found in Sec. 7.0 of Method 8260.

7.18 Quantitative analysis: See Method 8260 for overall information on alternative approaches to quantitation.

7.18.1 Calculate the amount in ng of each identified analyte from the VOST tubes following the guidance on calculations presented in Sec. 7.0 of Method 8260.

7.18.2 The choice of methods for evaluating data collected using the VOST methodology for incinerator trial burns is a regulatory decision. Contact the local regulatory agencies to which VOST data are submitted for information on data reporting preferences.

7.18.3 The total amount of the POHCs of interest collected on a pair of traps should be summed.

7.18.4 The occurrence of high concentrations of analytes on method blank cartridges indicates possible residual contamination of sorbent cartridges prior to shipment and use at the sampling site. Data with high associated blank values must be qualified with respect to validity, and all blank data should be reported separately. No blank corrections should be made in this case. Whether or not data of this type can be applied to the determination of destruction and removal efficiency is a regulatory decision. Continued observation of high concentrations of analytes on blank sorbent cartridges indicates that procedures for cleanup and quality control for the sampling tubes are inadequate. Corrective action must be applied to tube preparation and monitoring procedures to maintain method blank concentrations below detection limits for analytes.

7.18.5 Where applicable, an estimate of concentration for noncalibrated components in the sample may be made. Follow the guidance in Method 8260, Sec. 7.0 that covers this issue.

7.18.6 If any internal standard recoveries fall outside the control limits established in Section 8.4, data for all analytes determined for that cartridge(s) must be qualified with the observation. Report results without correction for surrogate compound recovery data. When duplicates are analyzed, report the data obtained with the sample results.

## 8.0 QUALITY CONTROL

8.1 Refer to Chapter One and Sec. 8.0 of Methods 5000 and 8000 for specific quality control procedures. Each laboratory using SW-846 methods should maintain a formal quality assurance program.

8.2 Before processing any samples, the analyst should demonstrate, through the analysis of a method blank (laboratory blank sorbent tubes, reagent water purge) that interferences from the analytical system, glassware, sorbent tube preparation, and reagents are under control. Each time a new batch of sorbent tubes is analyzed, a method blank should be processed as a safeguard against chronic laboratory contamination. Blank tubes which have been carried through all the stages of sorbent preparation and handling should be used in the analysis.

8.3 Initial Demonstration of Proficiency - Each laboratory must demonstrate initial proficiency with each sample preparation and determinative method combination it utilizes, by generating data of acceptable accuracy and precision for target analytes in a clean matrix. The laboratory should also repeat the following operations whenever new staff are trained or significant changes in instrumentation are made. See Sec. 8.0 of Methods 5000 and 8000 for information on how to accomplish this demonstration.

8.3.1 A reference sample concentrate is needed containing each analyte at a concentration of 10 mg/L in high purity methanol. The reference sample concentrate may be prepared from pure standard materials or purchased as certified solutions. If the reference sample concentrate is prepared by the laboratory, it must be prepared using stock standards prepared independently from the stock standards used for calibration.

8.3.2 Spike four pairs of cleaned, prepared VOST tubes with 10  $\mu$ L of the QC check sample concentrate and analyze these spiked VOST tubes according to the method beginning in Sec. 7.0.

8.3.3 Calculate the average recovery (X) in ng and the standard deviation of the recovery (s) in ng for each analyte using the results of the four analyses.

8.3.4 The average recovery and standard deviation must fall within the expected range for determination of volatile organic compounds using the VOST analytical methodology. The expected range for recovery of volatile organic compounds using this method is 50-150%. Standard deviation will be compound dependent, but should, in general, range from 15 to 30 ng. More detailed method performance criteria must be generated from historical records in the laboratory or from interlaboratory studies coordinated by the Environmental Protection Agency. Since the additional steps of sorbent tube spiking and desorption are superimposed upon the methodology of Method 8260, direct transposition of Method 8260 criteria is questionable. If the recovery and standard deviation for all analytes meet the acceptance

criteria, the system performance is acceptable and the analysis of field samples may begin. If any individual standard deviation exceeds the precision limit or any individual recovery falls outside the range for accuracy, then the system performance is unacceptable for that analyte. See also further information on this subject found in Method 8000, Sec. 8.0.

8.4 Sample Quality Control for Preparation and Analysis - See Sec. 8.0 in Method 5000 and Method 8000 for procedures to follow to demonstrate acceptable continuing performance on each set of samples to be analyzed. This includes the method blank (Sec. 8.2), a laboratory control sample (LCS) and the addition of surrogates to each sample and QC sample.

8.4.1 The LCS is prepared by spiking reference sample concentrate (noted in Sec. 8.3) onto a clean VOST tube.

8.4.2 If surrogate recovery is not within the limits established by the laboratory, the following procedures are necessary: (1) Verify that there are no errors in calculations, preparation of surrogate spiking solutions, and preparation of internal standard spiking solutions. Also, verify that instrument performance criteria have been met. (2) Recalculate the data and/or analyze a replicate sample, if replicates are available. (3) If all instrument performance criteria are met and recovery of surrogates from spiked blank VOST tubes (analysis of a method blank) is acceptable, the problem is due to the matrix. Emissions samples may be highly acidic and may be highly loaded with target and non target organic compounds. Both of these conditions will affect the ability to recover surrogate compounds which are spiked on the field samples. The surrogate compound recovery is thus a valuable indicator of the interactions of sampled compounds with the matrix. If surrogates spiked immediately before analysis cannot be observed with acceptable recovery, the implications for target organic analytes which have been sampled in the field must be assessed very carefully. If chemical or other interactions are occurring on the exposed tubes, the failure to observe an analyte may not necessarily imply that the DRE for that analyte is high.

## 9.0 METHOD PERFORMANCE

9.1 Method detection limit (MDL) is defined in Chapter One. The MDL actually achieved in a given analysis will vary depending upon instrument sensitivity and the effects of the matrix.

9.2 The MDL concentrations for VOST analytes can be found in Sec. 9.0 of Method 8260.

## 10.0 REFERENCES

1. Protocol for Collection and Analysis of Volatile POHCs Using VOST. EPA/600/8-84-007, March, 1984.
2. Validation of the Volatile Organic Sampling Train (VOST) Protocol. Volumes I and II. EPA/600/4-86-014A, January, 1986.
3. U.S. EPA 40 CFR Part 136, "Guidelines Establishing Test Procedures for Analysis of Pollutants Under the Clean Water Act, Method 624," October 26, 1984.

4. Bellar, T. A., and J.J. Lichtenberg, J. Amer. Water Works Assoc., 66(12), 739-744, 1974.
5. Bellar, T. A., and J.J. Lichtenberg, "Semi-Automated Headspace Analysis of Drinking Waters and Industrial Waters for Purgeable Volatile Organic Compounds," in Van Hall, ed., Measurement of Organic Pollutants in Water and Wastewater, ASTM STP 686, pp 108-129, 1979.

FIGURE 1  
CARTRIDGE DESORPTION FLOW

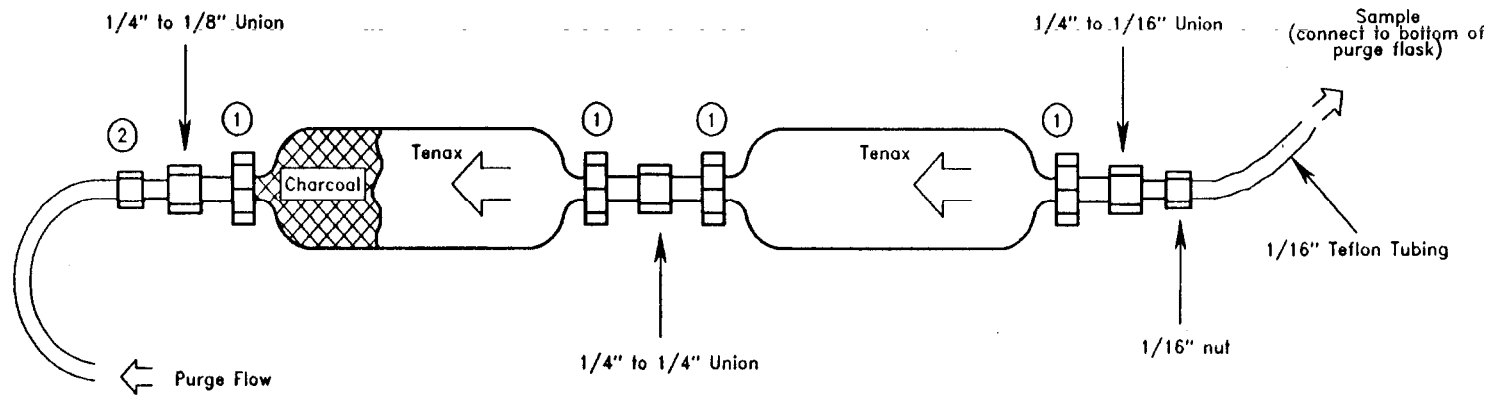

- |   |          |
|---|----------|
| ① | 1/4" nut |
| ② | 1/8" nut |

FIGURE 2

CARTRIDGE DESORPTION UNIT WITH PURGE AND TRAP UNIT

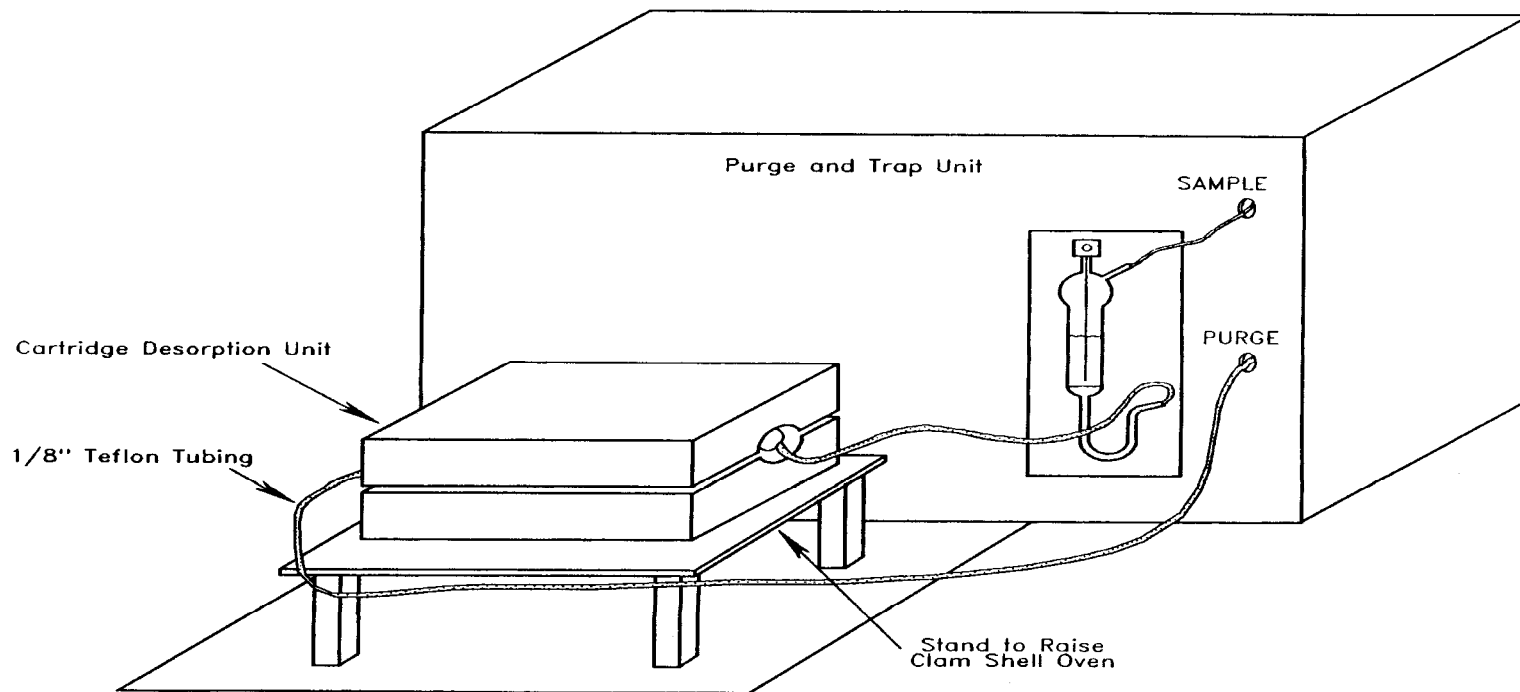



FIGURE 3

SCHEMATIC DIAGRAM OF ANALYTICAL SYSTEM

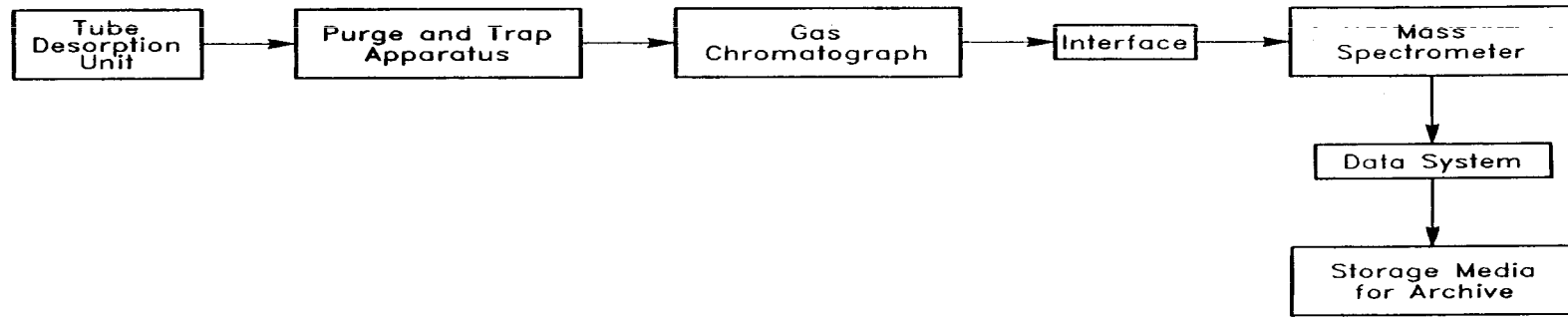

FIGURE 4  
SAMPLE PURGE VESSEL

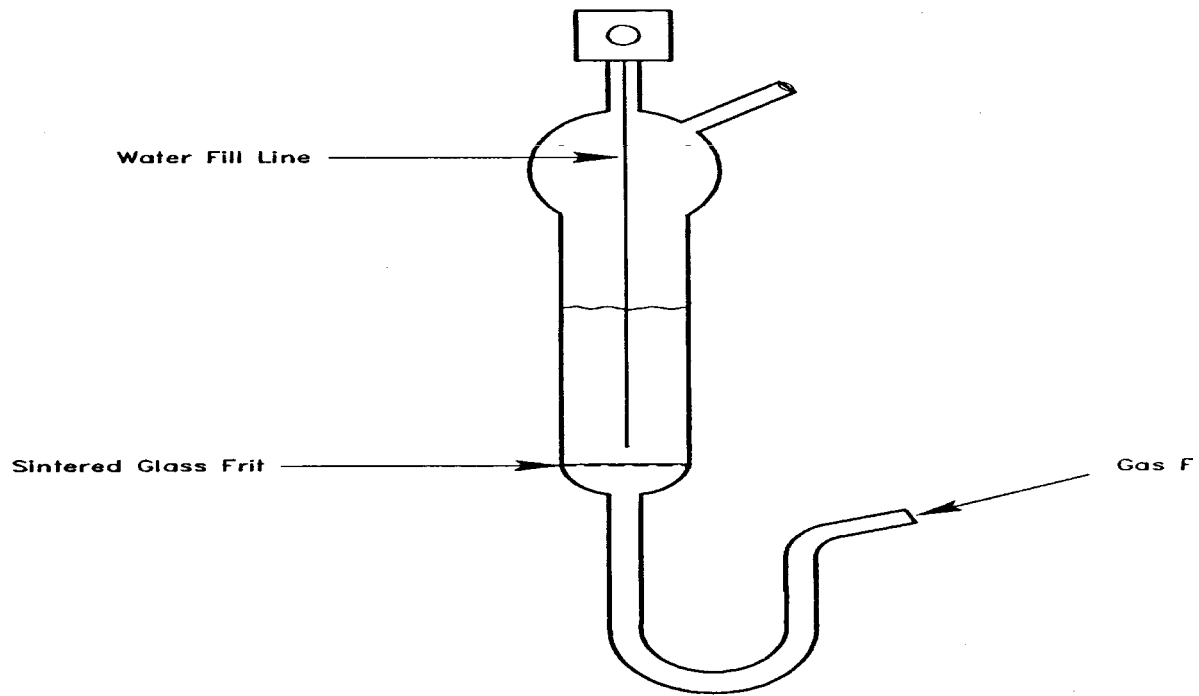
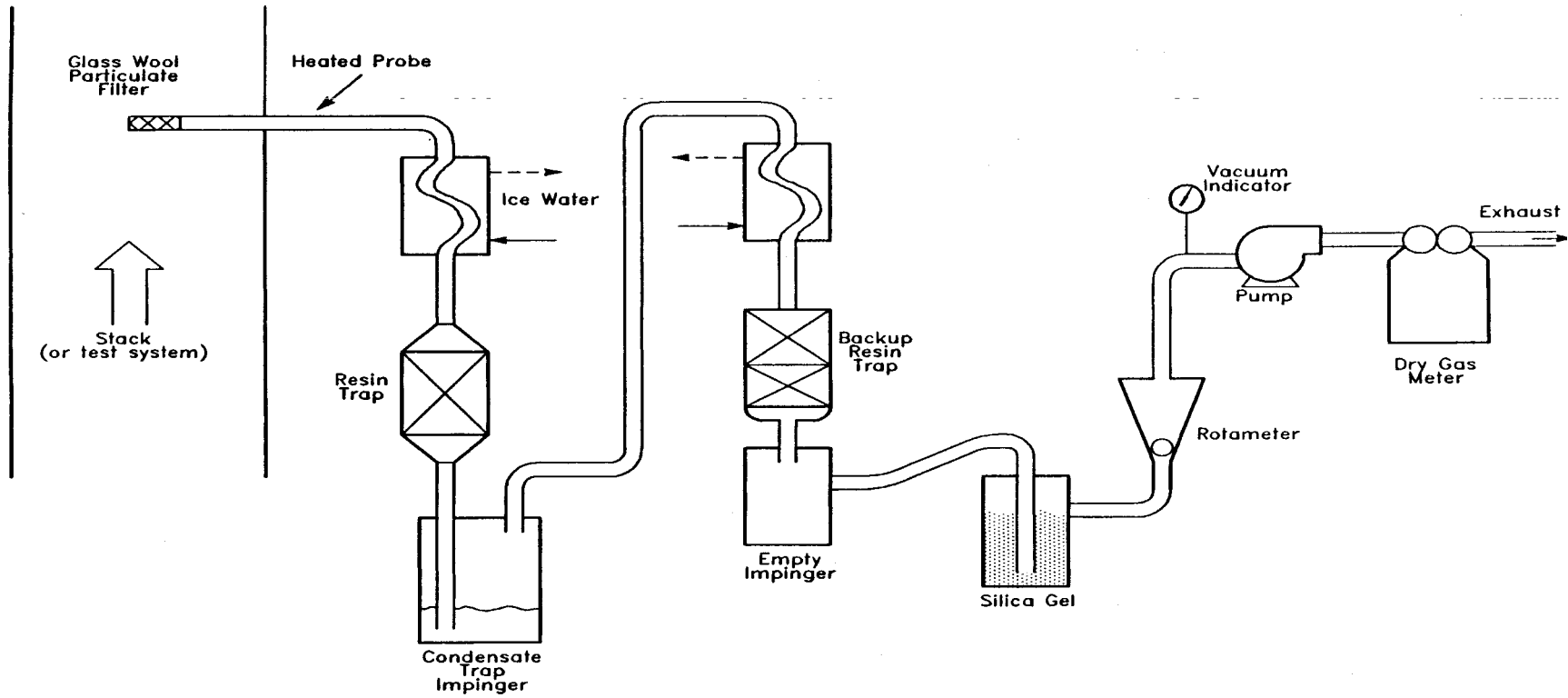

FIGURE 5

SCHEMATIC OF VOLATILE ORGANIC SAMPLING TRAIN (VOST)



METHOD 5041A

ANALYSIS FOR DESORPTION OF SORBENT CARTRIDGES FROM  
VOLATILE ORGANIC SAMPLING TRAIN (VOST)

